

the  
philadelphia  
association



newsletter feb 2018

# **PA NEWSLETTER**

## **FEBRUARY 2018**

### **CONTENTS**

<b>R.D. LAING'S TAPE RECORDINGS: A SECRETARIAL REMINISCENCE</b>	<b>1</b>	<b>POETRY AND PHOTOGRAPHY</b>	<b>27</b>
<b>BRETT KAHR</b>		<b>URSULA TROCHE</b>	
<b>I AM THEREFORE I RUN</b>	<b>5</b>	<b>FREEING THERAPY</b>	<b>29</b>
<b>PAUL GURNEY</b>		<b>PAUL GORDON</b>	
<b>OUTDOOR SPACES</b>	<b>10</b>	<b>PAINTINGS</b>	<b>31</b>
<b>CATHERINE STEVENS</b>		<b>LAURIE FITZGERALD</b>	
<b>VISIT TO INDIA</b>	<b>14</b>	<b>CATHÉRINE LASALMONIE</b>	
<b>ALISON DAVIES</b>		<b>EILEEN LY</b>	
<b>REPORT</b>	<b>16</b>	<b>THE ANXIETY BIND</b>	<b>35</b>
<b>AMANDA FEROZHA</b>		<b>JONATHAN ARMSTRONG</b>	
<b>A WORD OF WELCOME, A WORD OF WARNING</b>	<b>17</b>	<b>DRAWING</b>	<b>36</b>
<b>ROBBIE LOCKWOOD</b>		<b>SASKIA TANSY</b>	
<b>SUPPORTING OUR PA COMMUNITIES</b>	<b>21</b>	<b>PHOTOGRAPHY</b>	<b>37</b>
<b>LAKIS GEORGHIOU</b>		<b>ANDREA HEATH</b>	
<b>ELEANOR MARX: A LIFE PLAYED OUT AS TRAGEDY</b>	<b>23</b>	<b>MOVING BACK TO NOTTINGHAM AND FINDING LACAN</b>	<b>38</b>
<b>STEPHEN WOODHAMS</b>		<b>BECKY COLES</b>	
		<b>THE COST OF POSITIVE THINKING</b>	<b>40</b>
		<b>ROB WHITE</b>	
		<b>THE WORK</b>	<b>49</b>
		<b>NICK MERCER</b>	

**R.D. LAING'S  
TAPE RECORDINGS: A  
SECRETARIAL REMINISCENCE  
BRETT KAHR**

**“We visited their homes with a tape recorder and then a full-time secretary would transcribe the tapes”**

Dr. Ronald D. Laing

(Quoted in Mullan, 1995, p. 272)

In 1992, I became a member of the Mental Handicap Workshop and the Mental Handicap Team, based in the Child and Family Department at the Tavistock Clinic in North London. At that time, we referred to individuals suffering from disabilities as “mentally handicapped”, whereas today, we would, more commonly, deploy the terms “intellectually disabled” or “learning disabled”.

Shortly after having begun my work, Miss Janice Uphill, our long-standing secretary (whom we would, nowadays, style as an “administrative assistant”), had announced her retirement after approximately forty years, or thereabouts, and so we held a party in honour of this very kindly and gracious and efficient woman.

While chatting in our meeting room on the second floor, Janice began to reminisce about her lengthy period of services at the Tavistock Clinic. As a budding psychoanalytical historian, I took a keen interest in her stories about the old days and I even took notes. When I asked her how the Tavistock had changed since the 1950s, she replied immediately that, three decades previously, no one in the clinic knew very much about child abuse at all. Janice recalled, “Back

then, we thought that bed-wetting was the most severe variety of childhood neurosis”.

Strictly speaking, Miss Uphill’s recollection may not be entirely comprehensive, as I now know from my research in the archives of the Tavistock Clinic that physicians at the clinic had, indeed, worked with cases of what we would now deem to be child abuse (Kahr, 2000; cf. Dicks, 1970). But, in essence, Uphill spoke honestly, as during the 1950s and 1960s, very few clinicians recognised child abuse in the more astute way in which we do so today in the twenty-first century.

Janice Uphill recalled the many distinguished clinicians whom she knew, such as Dr. John Bowlby; and she also spoke about her work as secretary to Dr. Ronald Laing, then a

young psychiatric researcher at the Tavistock Clinic, specialising in the study of schizophrenia. As soon as Janice mentioned the name of Laing, my ears perked up considerably, as I had maintained a very long-standing interest in this extraordinary man and his work, and even had the privilege of meeting him, back in 1983, when I hosted his visit to the University of Oxford. Naturally, I asked Janice for further details about her work with this memorable personality.

Although, to the best of my knowledge, Miss Uphill never put pen to paper, I do believe that one of her memories of Laing deserves to be recorded in print, not for its potential gossip value but, rather, as a small, though important, contribution to our understanding of the psychodynamics of “madness”.

During the late 1950s, Laing began to research the nature of family interactions in households in which one person came to receive a diagnosis of schizophrenic psychosis. At that point in time, virtually all psychiatric and psychoanalytical work focused on the study and treatment of the single *individual*, rather than upon the *family* members at large. But Laing, a true pioneer of family psychology, decided to interview mothers and fathers and daughters and sons, all in the same room, and all at the same time. He even arranged to have these conversations recorded on tape, and Miss Uphill had the daunting task of transcribing precisely what the family had actually said.

The typing of these tapes might well have taxed Miss Uphill considerably. Certainly, Laing, in later

years, recalled that he became quite “exhausted” (quoted in Mullan, 1995, p. 304) simply from reading through the text of the interviews. In retrospect, I regret that I did not have the presence of mind to ask Janice whether the sheer transcription of the recordings of such troubled families had impacted upon her in an obvious way.

Eventually, Laing, in collaboration with his co-researcher Dr. Aaron Esterson, published his findings in the book *Sanity, Madness and the Family: Volume I. Families of Schizophrenics* (Laing and Esterson, 1964), which has since become a classic. The authors demonstrated very powerfully that madness may not result from a disordered brain, as many mid-twentieth-century psychiatrists had suggested but, rather,

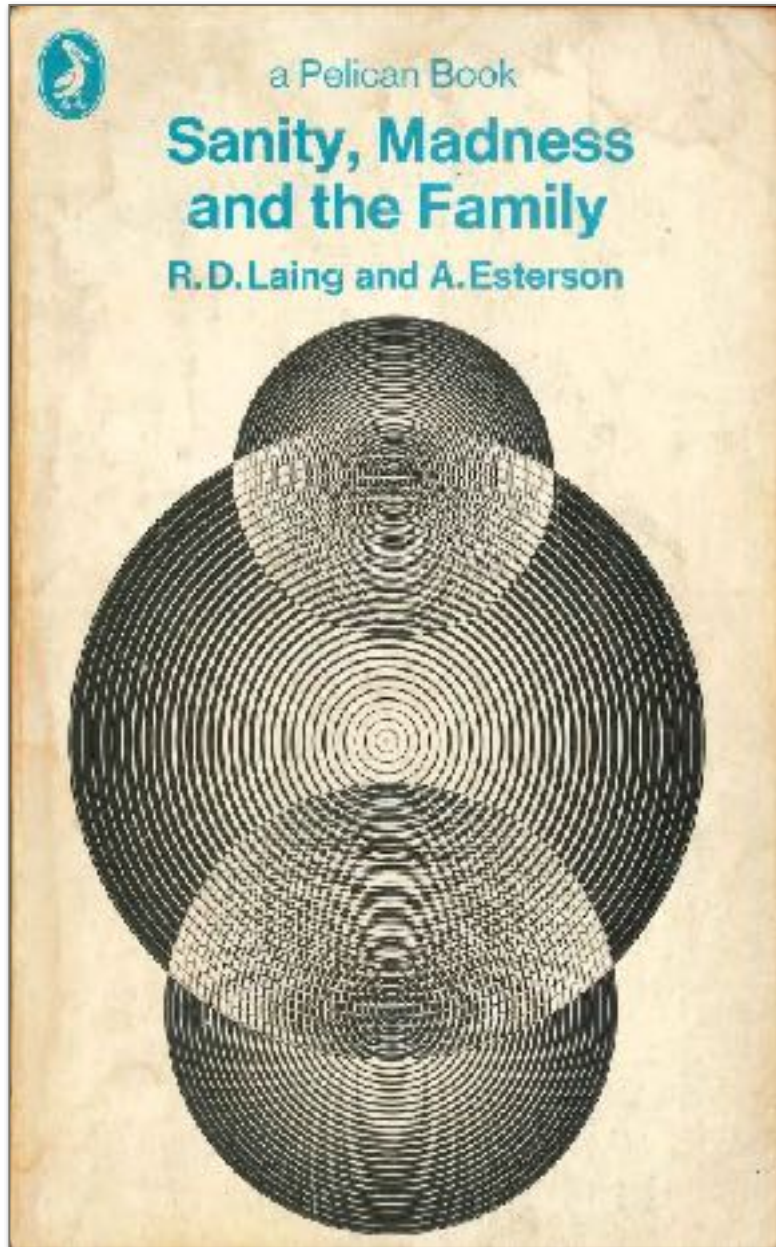

from the complexities of disturbances within the intimate nexus of the family.

Uphill explained that, at the time, many sceptics had criticised Laing hugely for his work, and many people believed that he had actually *forged* his data about the families of schizophrenics, arguing that no family system could possibly be *that* mad. But Uphill, who typed up all of the many pages of the transcripts, explained to me in no uncertain terms: “I can tell you that Laing did *not* make up his data. I

typed those tapes, and I can confirm that everything that he published in that book is actually true. Those families really did speak in that way”.

Although one must not place undue emphasis on a simple remark delivered in the midst of a noisy leaving-party, Miss Uphill’s comment about the raw data for Laing’s and Esterson’s masterwork left an indelible impression in my mind across the last quarter of a century. Uphill confirmed only too resolutely that Laing’s discoveries actually reveal something true and vital about the way in which madness might not reside entirely in the so-called “mad” person but, rather, can be located in the family system itself.

Interestingly, the secretarial staff at the Tavistock Clinic played an important role in the development of

Laing's work. According to Laing's own reminiscences (Mullan, 1995), one of the members of the clinic's secretarial pool typed up the final portions of the manuscript of his first and most landmark book *The Divided Self: A Study of Sanity and Madness* (Laing, 1960). And then Janice Uphill assisted him with the transcription work for what became *Sanity, Madness and the Family: Volume I. Families of Schizophrenics*. So, in spite of Laing's outspoken hostility towards many members of the psychological staff at the Tavistock Clinic (Mullan, 1995), that institution played a vital role, nevertheless, in the dissemination of his compelling *oeuvre*.

In recent years, Ronnie Laing's personal reputation has suffered considerably, and it has become all too

easy to dismiss his books as little more than 1960s left-wing, hippyish, drug-fuelled propaganda. But according to Janice Uphill, the young Tavistock Clinic psychiatrist had worked creatively and innovatively to capture the very fabric of the lives of troubled families. Such reminiscences will, I trust, provide some hope and encouragement to contemporary workers to persevere with an exploration of the hidden psychodynamics of family life.

*Copyright © 2017, by Professor Brett Kahr. Please do not quote without the permission of the author.*

## REFERENCES

- Dicks, Henry V. (1970). *Fifty Years of the Tavistock Clinic*. London: Routledge and Kegan Paul.
- Kahr, Brett (2000). "A Harley Street for the Anxious Poor": The Tavistock Clinic in the 1930s. *Psychotherapy Review*, 2, 397–99.
- Laing, Ronald D. (1960). *The Divided Self: A Study of Sanity and Madness*. London: Tavistock Publications.
- Laing, Ronald D., and Esterson, Aaron (1964). *Sanity, Madness and the Family: Volume I. Families of Schizophrenics*. London: Tavistock Publications.
- Mullan, Bob (1995). *Mad to Be Normal: Conversations with R. D. Laing*. London: Free Association Books.

## I AM THEREFORE I RUN

### PAUL GURNEY

It is my fifty-seventh birthday and I am running. Triumphant and astonished, I think – principally – of my parents: worn out at forty, dead in their sixties, subject to narrower cultural opportunities and the Compulsory Smoking Order then imposed on The Working Classes. I am running around the large park located just behind my house. Alchemical transformation from sewage works to nature reserve – grace of God, grace of Croydon council – as it was deemed to be too contaminated for “development”. Are the “foraged” foods – horseradish and blackberries – still contaminated thirty years on?

I run past dog-walkers (the “opposition”!) walled-in with blank nonrecognition, despite the inevitability of joining their ranks shortly: later I will be walking my big, old, slow dog and will therefore switch allegiance. (“I only recognise you when you’re with your dog!”). And the runners I have recently greeted will then eye me with suspicion (“Is he friendly?” “She!”). Grateful for the opportunity to occupy both positions, I am just about ready to emerge from the slurry of my internal monologue/meta-commentary and Look Around Me: the sky, the trees, the grass, the beer cans, the plastic bags, the amorously discarded items of clothing ...

I notice a twinge in my left calf muscle. I tell myself: “Stop running with your idealised body and run with

your fifty-seven-year-old Lacanian “fragmented” body:

**The Mirror Stage is a drama whose internal thrust is precipitated from insufficiency to anticipation – and which manufactures for the subject, caught up in the lure of spatial identification, the succession of fantasies that extends from a fragmented body-image to a form of its totality that I shall call orthopaedic – and, lastly, to the assumption of the armour of an alienating identity, which will mark with its rigid structure the subject’s entire mental development.**

(Lacan, 1977, p. 4)

The twinge disappears. Technologically (as Foucault might say)–

Technologies of the self, which permit individuals to effect by their own means, or with the help of others, a certain number of operations on their own bodies and souls, thoughts, conduct, and way of being, so as to transform themselves in order to attain a certain state of happiness, purity, wisdom, perfection, or immortality.  
(Foucault, 1977, p. 225)

–and somewhat belatedly, I attempt to undo four hundred years of “Cartesian” dualism:

And because no other equally convenient way of explaining it occurs to me, I therefore conclude with great probability that the body exists. But this is only a probability, and although I am investigating the

whole matter with great care, I do not yet see that, from this distinct idea of bodily nature that I find in my imagination, any argument can be derived that will lead necessarily to the conclusion that some body exists.  
(Descartes, 2008, p. 52)

I run, therefore I am?

(I ask a patient, “And how did your body feel about it? Your body was there, too!” A fit of coughing ensues. And of course all my bodies – imaginary and fragmented – are there in my consulting room, hour after hour, sitting still, while I attempt to administer the “talking cure”.) My idealised body has come a cropper before. At the age of thirty-eight I “do my knee in” playing squash: a grudge match, a tense rush-hour drive,

straight on court, “No I don’t need to warm up!” (I am omnipotent), hubris: ouch!

By chance and personal recommendation, I buy my running shoes from a Buddhist running shop. And yoga seems to offset the likelihood of “occupational hazard” injury. Balance in all things. Aristotle would be proud!

**We have now sufficiently shown that ... virtue is a mean, and in what sense it is so; that it is a mean as lying between two vices, a vice of excess on the one side and a vice of deficiency on the other, and as aiming at the mean in emotion and action.**

(Aristotle, 1943, p. 111)





In an additional attempt at balance, I run essentially on grass (and mud!). Softer, and the uneven surface vouchsafing against “repetitive strain injury”: some years ago, a medical colleague who in his youth had represented his African country of origin internationally as a long-distance runner, and who was given to running through the bush in bare feet, advised me thus. Who am I to spurn such wisdom?

But the best thing about running is that I’m not very good at it. “The brightest jewel inside of me glows with pleasure at my own stupidity” (Devoto, 1980). My adult life: littered with abandoned hobbies at the point when someone said, “You could

be really good at this if you practiced/trained/studied more” ... my work is something I practice/train/study/take seriously. I have no need for something else to be as difficult: enough of life is like that, anyway.

And I wasn't any good at running at school, either: because I was “brainy” – and had clapped-out parents – I persuaded myself I couldn't be “sporty” as well. Not that either of these handicaps prevented my (younger) brother from being both: I got lost in a hall of mirrors of my own making.

I don't time myself or know how far I run. My “personal bests”: one (too long and boring) half-marathon in one hour fifty-eight minutes, achieved only due to the sacrifice of my then boss, coaxing and cajoling me to a mixture of eight-and-nine-minute

miles when he could have been doing sevens; my first “10k” in forty-four, then a drift during middle age to several fifty-nines and A ROD FOR MY OWN BACK. I WILL NOT SLIP OVER THE HOUR UNTIL I'M SIXTY! In the most recent race I resolve to SPARE THE ROD and TAKE AS LONG AS IT TAKES, and ENJOY MYSELF. But, as I enter the Last Lap, an old, familiar imperative steals over me and I speed up, running as fast as I can until I feel sick. Like I'm ten-year-old Paddy Clarke (Doyle, 1993) or something:

... we'd been pushing bricks into a trench full of wet cement when Aidan started running away. We could hear his asthma, and we all ran as well. We were being chased. I had to wait for Sinbad. I looked back and there was no-one after us

but I didn't say anything. I grabbed Sinbad's hand and ran and caught up with the rest of them. We stopped when we got out of the fields onto the end of the road. We laughed. We roared through the gap in the hedge.

(Doyle, 1993, p. 2)

Fifty-eight minutes and nineteen seconds: a whole minute off the previous time. I am not immune. Why did I ever think I could/should be?

“It's not about you joggers who go round and round and round” (Blur, 1994).

*Isn't it?*

And what do I think about when I'm running? Is it my desire “to wrap the king in a blanketing silence, so that he ... can listen to himself” (Mantel, 2009, p. 340). To “knit up the ravelled

sleeve of care” (Shakespeare, 1997)? I remember, repeat, work through (occasionally) (Freud, 1914). Self-analysis, supervision, emotional regulation, discharge, abreaction ... sometimes NOTHING.

A while ago, I was saying to a colleague that it often felt that I could “work things through” in relation to work more effectively while running. She, of the EMDR (Eye Movement Desensitising and Reprocessing?) and PTSD (Post-Traumatic Stress Disorder) community, said “Well that would fit with the neuroscience: left/right, left/right ...”, referring I imagine to the belief (evidence?) that in order to “process” something healthily, we need to engage our body/brain – for they are the same, of course – in its service. Like the Okey-Cokey ...?

## REFERENCES

- Lacan, Jacques (1977 [1949]). “The mirror stage as formative of the function of the I,” in *Ecrits: a Selection*, trans. Alan Sheridan. London, Routledge.
- Foucault, Michel (1997 [1982]). “Technologies of the Self” in *Ethics: the Essential Works I*, ed. Paul Rabinow, trans. Robert Hurley, London: Penguin.
- Descartes, René (2008 [1641]). *Meditations on First Philosophy*, trans. Michael Moriarty. Oxford: Oxford University Press.
- Aristotle (1943 [350 BC]). *Nicomachean Ethics in On Man in the Universe*, ed. Louise Ropes Loomis. New Jersey: Gramercy
- Magazine (1980). “A Song From Under the Floorboards,” on *The Correct Use of Soap*. Virgin.
- Mantel, Hilary (2009). *Wolf Hall*. London: Fourth Estate.
- Shakespeare, William (1997 [1606]). *Macbeth*, ed. Kenneth Muir. London: Arden.
- Doyle, Roddy (1993). *Paddy Clarke Ha Ha Ha*. London: Vintage.
- Blur (1994). “Parklife”, on *Parklife*. Food.
- Freud, Sigmund (1914). “Remembering, Repeating and Working Through.” *Standard Edition*, vol. 12.

## OUTDOOR SPACES

### CATHERINE STEVENS

**“A Garden is the purest of human pleasures. It is the greatest refreshment to the spirits of man [woman], without which buildings and palaces are but gross handiworks.”**  
Francis Bacon

*I am a community gardener and horticultural art therapist working at Brockwell Park Community*

*Greenhouses in South London. I very much appreciate being invited to write for the PA newsletter and the welcome into the PA extended community. I regularly attend film evenings and events and have supported the charity by donating art materials to the community houses.*

*Nature is filled with patterning, recurring motives, and themes with*



*almost endless variations. Cycles of becoming, growth and unfolding followed by flowering, maturity, ripening of fruit and seed to ensure a next generation, followed by decline, death, and decomposition.*

*Decomposition can be considered under different names. Gardeners might call it composting, horticulturalists and biochemists*

*might call it the “nitrogen cycle”, environmentalists may call it “recycling” and so forth, which in turn gives rise to the beginning of new generations of seeds, ideas, and variations on themes. These are all metaphors of living processes and we would argue are life-supporting and life-sustaining.*



*One important aspect of this can be seen when we look at outdoor spaces from a horticultural and environmental perspective. For example Kew Garden's Breathing Planet Campaign in which David Attenborough eloquently makes the case for why it is so important that we learn to respect and protect our natural environment worldwide because "all life depends on plants". They are the base of the food chain, the ultimate autotrophs upon which all other creatures depend, including ourselves. We cannot live without them, they produce the oxygen we breathe, the food we eat and the fuel we burn, so it does matter that we are destroying many natural habitats and if we wish to reverse this trend, which we surely do, we must first understand what it is we are harming. The*

*Breathing Planet Campaign suggests that to protect plants and the earth we must engage with them and gardening is a very good way to do just that. So once again nature and the living environment mirrors something back to us.*

*For all our technology, a relatively recent development in the history of mankind, with its mechanical metaphors of alienation, when gardening we can reconnect to the rich reserve of nature's metaphors that speaks to the artist in us with stories of belonging and finding our place in the world, metaphors that embrace our humanity and facilitate our passage through the different stages of our lives, from generation to generation.*

*The use of outdoor spaces is significant for us for many different*

*reasons. For some, the significance of getting out of the isolation of living mainly in our heads, alone, in flats cut off from a sense of community (particularly in cities). Community gardening offers a possibility of being in our bodies, reality testing with others and being open to the surprises natural living processes bring.*

*Borrowing a metaphor from the realm of ecology and organic gardening, what we can observe from art and gardening is that the more complex the systems, the more stable and resilient they are. This could be said of both organic gardening and social systems like a community group, where the complexities of reciprocal relationships and the finely tuned sense of balance enables these to be sustainable. In both these contexts, oversimplification damages*

*resilience, creativity and sustainability.*

*Without this connection and living engagement with the dynamic environment around us we are indeed dis-eased.*

*Plants grow in real time, and psychological change happens in real time too.*

*See to the right the poster for the therapeutic Friday gardening group I will be starting at Brockwell Park Community Greenhouses in March. These will be weekly groups that run from March till October. They are set in our gardens, and join up with other community gardening activities and events we run through out the year. See our website:*

[brockwellgreenhouses.org.uk](http://brockwellgreenhouses.org.uk)

*for our programme of community events and workshops. If anyone is*

*interested in trying out Better Fridays gardening group they can give us a ring or email us.*

**Brockwell Park Community Greenhouses**  
Registered Charity no. 114098

**Better Fridays**  
Garden therapy sessions with Cat and Cathy

Funded by  
The Garden Community Foundation

**BETTER FRIDAYS**

FEELING A BIT LOW?  
LIKE TO GET OUT & ENJOY NATURE?  
FANCY HELPING TO GROW, COOK & EAT TASTY VEG?  
JOIN CAT & CATHY FOR A SPOT OF GARDENING & A HOME COOKED LUNCH

FRIDAYS 10.30AM – 1.30PM FROM 23RD MARCH  
INTRODUCTORY SESSIONS 9TH & 16TH MARCH

CONTACT CATHY ON  
EDULASSISTANT@BROCKWELLGREENHOUSES.ORG.UK  
OR TEL. 07834 343664, 07503 919973

GardenBrockwell  
BrockwellParkCommunityGreenhouses  
www.brockwellgreenhouses.org.uk  
brockwell\_greenhouses  
Community Greenhouses, Brockwell Park, London SE24 9BJ

We are in the middle of Brockwell Park, between the tennis courts and the walled garden. Follow the signposts to the Community Greenhouses.

## VISIT TO INDIA

### ALISON DAVIES

*This January I spent three weeks in Mamillapuram in India, South of Chennai (Madras). I go each Christmas mainly to continue my interest in stone-carving, which is an art that is practised in this area of India. This visit, in the time off between hard work carving granite stone, I visited various projects that are taking place mostly to help Indian people that live in the scattered villages and often at the margins of society.*

*One such project is an art project that takes place in a settlement three kilometres from a very small town called Chengelpattu. This is where Bindu Art School is situated, an*

*art school with a difference. All students have suffered from leprosy, with ages between 25 and 94. This is an initiative founded by an Austrian, Werner Dornick, a multimedia artist and curator. He runs it together with his partner Dagmar Vogl.*

*Werner explained to me that he visited South India as a young hippy in the seventies and was moved by seeing the extent of poverty and discrimination particularly amongst the people with leprosy. Feeling privileged with a wallet in his back pocket and able to travel around with no financial constraints, he decided that he would come back to India and help these suffering people, his interest being in inspiring people with leprosy through creativity. Although there is now a cure for leprosy there is*

*still discrimination towards those that have or have had leprosy: many still experience being outcasts in society. In India 500,000 people have been infected with leprosy over the last twenty years. They live as “untouchables”.*

*The art therapy project Werner spearheads with social activist Padma Venkataraman, is described by him as a new way of life for these people, “a resurrection into life, in which they are met with esteem and respect”. It takes place daily in a small low-lying building in the village of Bharatapuram. Students come from various religions and are mostly illiterate. They begin each day with meditation.*

*I watched students painting the most beautiful paintings, sometimes scenes of village life, sometimes*



*fantasy and intricate designs. They were clearly all absorbed in their work. The celebration of colour in their paintings was joyful and very beautiful. The paintings were for sale. The students are encouraged to deal with their own financial transactions as an effort towards more independence. This helps them to feel autonomous without the discrimination of receiving alms. I bought a beautiful painting from an elderly lady called T. Rajaswiri (see photo) of a design of blue birds, totally imaginative and spontaneous with a beauty that is very striking. The money from the sale of the pictures mostly goes to the artist but some is ploughed back into the project for materials, transport, framing and administration.*



*For further information regarding this project and to see a gallery of paintings produced and a short film, visit: [www.bindu-art.at](http://www.bindu-art.at)*

## REPORT

### AMANDA FERROZHA

*I attended the 20 January 2018 delegate meeting of the UKCP Council for Psychotherapy and Jungian Analysis College.*

*The PA is a training Organisational Member (OM) of the CPJA College of the UKCP and I am currently the PA delegate at these meetings, which take place approximately four times a year. According to the UKCP “colleges are collections of members – organizational or individual – who share a philosophy of psychotherapy. Each college holds standards for education, training and practice that are compatible with UKCP’s generic standards and with the individual college’s philosophy.*

*Colleges are responsible for accepting applicants into full membership of UKCP and all existing members must belong to a college. There are in total eleven UKCP colleges.*

*The OMs of the college were asked earlier in the year to respond to a request to complete a survey looking at the truth behind some of the myths about successes and failures of our trainings. The conclusion was that it is a misconception that all psychoanalytic trainings offer the same kind of training and that it is not accepted that one stance is necessarily better or more right than the other, but that “true to honouring the disagreement between Freud and Carl Jung, CPJA’s name attempts to offer our stance that neither one of their teachings is more right than the other.*

*In fact a pluralistic approach is much wider than this with the CPJA embracing psychodynamic psychotherapy, group analytic psychotherapy as well as psychoanalytic and Jungian analytic thinking”*

*It was noted that, in spite of the successes of training, some of the smaller organizations were struggling to survive by attracting enough candidates to make running the training financially viable. One such organization is the Canterbury Consortium of Psychoanalytic and Psychodynamic Psychotherapists (CCoPPP) and part of their unfortunate closure may have been due to loss of recognition from the University of Kent.*

*At the meeting there was a general conversation about the value*

*of psychoanalysis (something which has been regularly on the agenda since I joined as a delegate a year ago). The question came up: how to convey the value of psychoanalysis, both in terms of trainings and of being the patient, but without being defensive? The issues of use of marketing, social media, and the use of language were discussed. The general public is the main recipient of these forms of communication so language needs to support this. So how do we talk about what we do as psychotherapists, what language do we use to convey what we do or how we think in terms the general public can relate to? What can be said about an experience that can neither be weighed nor measured but needs to be experienced and made sense of by each individual alone? How does*

*psychoanalytic thinking, which takes into account the unknown and mysterious unconscious, fit into an increasingly scientific evidence-based world that wants to prove everything, yet denies the mysterious? And will we be accused of being too “vague” or “woolly” if we do not try to articulate what psychoanalysis is about in purely scientific terms?*

## **A WORD OF WELCOME, A WORD OF WARNING**

### **ROBBIE LOCKWOOD**

**Astonishment is the precise name for what Derrida’s speaking calls forth in us. It forces us finally to think, and no longer to imagine that we are thinking. I add that it also takes the risk of the other in the play of the seminar. It accepts the risk of being wrongly understood ... to inaugurate a dialogue where nothing was planned. I would like to salute the audacity that leads a philosophical utterance to make us desert those dwellings of the mind where reason lives as master, when for an instant astonishment makes reason a guest.**

(Derrida and Dufourmantelle, 2000,  
pp. 32–36)

The words above are those of philosopher and psychoanalyst Anne Dufourmantelle; her “invitation” is a response to Jacques Derrida’s two

seminars on the theme of hospitality in the same book. It could be enough to just list some of the words in the quote above which may resonate with “us” at the Philadelphia Association (PA) (“us” as the PA, or the PA as a version of an “us”?): astonishment; calling forth; thinking; imagination; risk; play; (mis)understanding; inauguration; dialogue; salutation; audacity; utterance; dwelling; guest. Two words missing in this quote but very present in their book, are gentleness and, perhaps a cousin of gentleness, *humility*. It is a theme to be continued in Dufourmantelle’s *Power of Gentleness: Meditations on the Risk of Living*.

When I happened upon this forthcoming translation, I wondered about sending an invitation to Dufourmantelle, to respond with “us”

at the PA, to call forth and misunderstand this new translation together; it is due for release in March. It seemed to me for many reasons, an important time for “us” to come together, to invite this stranger, to dwell on these themes together. When searching for a contact, I was shocked to read of her untimely death, just this summer past, taken by the sea whilst attempting to save two children in dangerous waters; the children were subsequently rescued. The irony of her death cannot be lost when considering her dedication to the themes of the *risk of living*, and as above, *the risk of the other*, which is made explicit both in her writing on action and in this action towards her death, as the *risk of the other, for the other*. The necessity of risk in welcoming the stranger/foreigner is one of Derrida’s themes

that Dufourmantelle meditates on; the children that she risked and lost her life for were strangers to her.

Derrida riffs on the Latin *hostis*, meaning guest, stranger *and* enemy; it is of course related to both host *and* hostage, giving presence to the fluidity in which one risks becoming, creating a space for, the other – the host welcomes the guest, who risks becoming hostage; but also as in Homer’s *Odyssey*, the host is always at risk of being taken hostage by its guests. It was in response to the death of Emmanuel Levinas that Derrida meditated on the theme of *welcoming* in his essay “A Word of Welcome” in *Adieu To Emmanuel Levinas*; the seminars for this as well as those in *Of Hospitality* began to take place a year after Levinas’s death.



As briefly mentioned by Ian McMillan in the previous newsletter, the inaugurating newsletter, one of the founders of the PA's training, John Heaton, died at the end of spring last

**PA NEWSLETTER**

year. He was still that year accepting, responding to, the invitation to invite, to welcome trainees, into a dialogue, to respond to his ways toward understanding. Few, surely, could

argue against it having been an honour to be in conversation with him, and few, surely, could question his humility.

So in the face of death, welcoming and the risk of hospitality, might have already been opened for renewed thought and action today at the PA and thanks are due to Andrea and Rob for beginning and maintaining this newsletter, this invitation that is always already a response. For a tiny organization like the PA, with minimal structures, who welcomes and who responds to the responsibilities here, seem fraught with danger – one simple but devastating danger, being Derrida's description for the experience of death, *the survivor of the other who responds no longer*, the experience of the without-response. Whose

responsibility toward each seminar leader, who is both our guest and also host of whatever (mis)understanding they bring for dialogue; toward each person seeking and receiving therapy with a PA member; to a training that may be like no other in the country, perhaps at constant risk of becoming like any other; to a rich but contentious PA history, its legacy of people and its ways toward understanding; to the community houses, residents and therapists and the very buildings donated or bought (at least one, The Grove, through an elaborate fundraising event in 1972 – Gordon, 2010, p. 33); how to respond to the fact that most of the above are situated in London (of course, not all PA members are based here), this capital city (one of capitalism’s capitals – *caput* – is root for head and

also, perhaps promisingly, slang for dead) where welcoming the stranger, especially the stranger to financial assets, might seem less and less possible at present.

Whether a reading group, a conference, or some other welcoming, it might be worth coming together again, to think about hospitality, our hospitality or our lack thereof, to wonder if an “us” or “we” have any legitimacy “here,” and what might be the consequences if not – if “us” and “we” must forever remain in quotation marks? Do get in touch if you would like to contribute to putting something together to further this dialogue: [rlockwoodtherapy@gmail.com](mailto:rlockwoodtherapy@gmail.com).

## REFERENCES

- Derrida, Jacques and Dufourmantelle, Anne (2000). *Of Hospitality*, trans. Rachel Bowlby. Stanford, CA: Stanford University Press, (2000)
- Derrida, Jacques (1999). *Adieu to Emmanuel Levinas*, trans. Pascale-Anne Brault and Michael Naas. Stanford CA: Stanford University Press.
- Dufourmantelle, Anne (2018). *Power of Gentleness: Meditations on the Risk of Living*, trans. Katherine Payne and Vincent Sallé. New York: Fordham University Press.
- Gordon, Paul (2010). *An Uneasy Dwelling*. Monmouth: PCCS Books.

## **SUPPORTING OUR PA COMMUNITIES**

### **LAKIS GEORGHIOU**

*Freegrove Road and The Grove are the only two houses left in a long list of community houses that the PA once set up to undertake its charitable aims. As a trainee, I did my placement at The Grove and came to appreciate the difficult, yet potentially life-changing experiences of living as a community for many residents. With the support of the House Therapists at the time, I suggested to the residents that we share a meal together during the house meeting that I was attending. This, I have been told, was a weekly tradition at Shirland Road on a Sunday.*

*It started simply with offers of crisps, hummus and carrots but by the end of my placement, pork stews and*



*curries were being made one resident. Sometimes others would help me to make fresh pizza bases with different toppings. The sharing of a meal even during difficult moments made I feel a palpable difference to the sense of community and brother/sisterhood. Food as the uniting metaphor of experience perhaps.*

*We have heard much said about the relevance of the PA houses today. Could the charity use its capital resources in a better way to support emotional suffering? Are the PA Communities using the same model they once did; should they still be? These are rich and valuable questions that should be debated.*

*Last year, however, a crisis was reached in the houses' financial position, made desperate by under-occupancy. For the first time that I can remember, discussion turned to, and the trustees focussed attention on, the possibility of closing one of them.*

*Some members were very distressed at the thought of this and pledged to do their utmost to avoid this outcome. A five-year plan was considered and occupancy has dramatically recovered. The houses are back on an even keel financially and the threat of closure has been averted.*

*I am currently helping on the Houses Committee as Houses Manager. Over the last eighteen months, we have reviewed as a team all the Health and Safety and general maintenance governance for both houses. Our new administrator has been instrumental in helping to deal with utility companies, electrical and fire-safety documents and tenancies.*

*Last summer, we received an overdue complaint from the neighbouring property about the state of ivy which had grown up three stories to the roof at Freegrove Road. It had started to invade their house.*

*The insects and wasps that found their shelter were flying into bedrooms at night time and there was a terrible smell in our house which meant that the room affected could not be rented out.*

*One scaffolding company, a wasp-nest-removal specialist, followed later by a tree surgeon, ensured that the ivy has now gone.*

*The root of the ivy had entwined itself alongside a healthy vine which also sadly required removal. This did away any chance of me showing the residents how to stuff the vine leaves as Greek cuisine dictates!*



## **ELEANOR MARX: A LIFE PLAYED OUT AS TRAGEDY**

**STEPHEN WOODHAMS**

Eleanor Marx, the brilliant and tragic daughter was Karl's favourite. Her birth near coincided with the death of another Marx child, Edgar. The three remaining children, all girls, making it beyond infancy included Laura and the eldest, Jenny, named after her mother. Each in their fashion had tragic adult lives, Jenny and Laura marrying badly to men who offered little as partners or fathers. However, it is Eleanor who has always captured the biographer and historian's attention. Perhaps there is something of the enigma quality to the brilliant young women, chosen by her father to be the offspring on whom he bestowed

his deepest love and greatest expectation. Her too brief adult life was that of a shooting star, lighting the firmament as she broke the gender rules and defied the lore of her time to be the woman on platforms of men addressing the industrial working class in London and beyond. Around her were the men who headed the trade unions, inspired the fledgling socialist movements, and led working people against police baton and judicial prejudice. Tom Mann and William Morris, to name but two of the best known, were leaders with whom Eleanor stood equal in the cause. Eleanor Marx's relation with the emerging women's movements were more problematic. On the one hand were those who would come to see the vote as the essential key to liberation, on the other were such as the Co-

operative Women's Guild who saw social reform as first importance. If the first expressed the desire of in the main middle class women at this time, the latter was an organisation led by the skilled and respectable working class. Eleanor Marx's heart was with the latter, yet she mixed with higher-educated women and shared their culture.

Biographies of Eleanor include the two-volume labour of love by Yvonne Kapp which has recently been joined by, at least to the present writer, a surprisingly good volume by Rachel Holmes. Perhaps a small confession might not be amiss. I first heard of the new biography when it was to be serialised on Radio 4. My prejudice was that if the BBC were going to broadcast a biography of a Marx, then it was going to be a hatchet job on all

things left of Tony Blair. I was wrong. Holmes has gone back to primary sources and produced a fine historical work. Biography can be written in many forms. Among the worst is the pop psychology that offers to “understand” their subject according to some bit of textbook wisdom, telling the reader that all can be made sense of if we take into account the manner of the figure’s potty training. Yvonne Kapp and Rachel Holmes practice the historians’ craft, they have each done their time in the archives weeding through papers. The results are works of quality.

Tussy, pronounced we are told, to rhyme with pussy, was the name given to the young child born at 28 Dean Street, Soho on Tuesday 16 January 1855. A year later, the family escaped to the comparative calm of

Hampstead. The Marxes’ lives, as is well known, continued for most of Tussy’s childhood as it had previously, in debt. Jenny Marx was a woman of bourgeois temperament and tastes; unfortunately, her spending matched, with the result that Karl would have had to earn an income of bourgeois measure. He did not. It has to be admitted that the reason in part at least was because Jenny would not allow him to undertake writing for money when the great work of *Capital* was yet unfinished. She was as committed to Karl’s writing as he, and there is little doubt that his labours and the family’s sufferings were jointly shared. Fending off intimidating figures at the house demanding money for groceries or clothes was made possible by the lifelong friend Frederick Engels. The Manchester-

based factory owner sent frequent sums to keep the wolves from the door and the girls in at least some measure of bourgeois lifestyle. They attended South Hampstead College for Ladies, pursuing at least some of the arts expected of young ladies. For Tussy though, real learning though was at home. Karl fussed over her, playing the indulgent father who loved nothing more than caper with his favourite child. Their intimacy soon grew in sophistication, as they wrote letters to each other expressing views not only on matters of home and those around the family but world affairs. Young Tussy clearly gained rapid confidence from her exchanges with Karl, and wrote to advise Abraham Lincoln on the terms of the war with the Rebel South – not something many children would venture. Respectable

Sunday leisure meanwhile meant walks up the Heath.

It is not possible for the biographer to know all that occurs in the life of a subject. There is a private sphere that rightly remains beyond known fact and where the writer has to accept informed reasoning may be the best attainable. Such is the case with Eleanor Marx's health. We know she suffered a severe bout of whooping cough to which many infants in the mid-nineteenth century succumbed. Eleanor's constitution and intense nursing brought her through. What happened later is less certain but childhood depression does at least seem a reasoned possibility during her early years. More certain, is that she suffered intermittent depressive moods in adulthood. What is common knowledge however is the utterly

appalling treatment Eleanor suffered at the hands of her lover Edward Aveling, and that it was he who effectively caused her to take her life. There is no need here to repeat the catalogue of humiliation to which Eleanor was put by Aveling's behaviour, the summation of which has entered the folklore of the left.

Of interest then is the personality of this undoubtedly brilliant young woman. Her learning may have been largely informal, but which with one of the greatest minds of the century as tutor, would have gone far beyond anything a university could have offered. Her work for others (she earned her own income) in the British Library was mixed with her own writing and translating. She



addressed socialist meetings and working-class crowds frequently and for some years assisted her father and Frederick Engels in their work. This last was made the more continuous, after Engels made his home at Primrose Hill having given up the Manchester works.

She engaged, too, wholeheartedly in welfare work for the Communards, many of who were starving on the streets of London. She had herself been arrested in France on political grounds and only the intelligence of the sisters kept them from considerable suffering. The fraught relations between Engels and William Morris while tense for the young women would have been made the more difficult by their independent assessment of Aveling as a villain. This accurate evaluation of him from

those closest to her was borne by Eleanor with courage that may have been greater than those around her could have guessed, as commitment and sheer hard graft perhaps kept the gripping fingers of depression at bay. Her times away from London seemed to have been enjoyed, especially that in the Warwickshire where she took on the practical life of country woman, growing and making food from that to hand. In London, work was mixed with social gathering into which she threw herself fully. Yet the sorrow that may have started in childhood to be much exacerbated by a cruel and callous man whom she loved, was perhaps always there; of more we cannot be sure. Eleanor lived at a time when prejudice against “mental illness” was normal. Perhaps even her father, a man as advanced in thinking

as any bourgeois male of his time, wished to ignore his daughter’s suffering, rather than admit her difficulties. And, there may of course have been her own self-denial, at least until the world became too bitter, the cruelty of another too much to bear. Did love blind her from making the break from Aveling and building a life for which she had all the skills? We are left with questions that now may never be answered. What perhaps the life of Eleanor Marx may teach us is the complexity of human personality where contradictions can lie unanswered and unresolved. Commitment, brilliance, enthusiasm can mix with fragility, emotional insecurity and experience of pain. Eleanor Marx was remarkable, yet like us all, still human.

## POETRY AND PHOTOGRAPHY

### URSULA TROCHE

*I know about the work of the Philadelphia Association because I attended the PA introductory course and regularly attend PA events. Here is a poem I wrote called “Our Caves” – it shows my psychoanalytic interest, which constantly informs my poetry, and has done ever since I started writing. I call myself a psychogeographer, as psychogeography combines the psych- with place, art and writing.*

#### OUR CAVES

I go where the transitions are  
Unexposed landmarks, like  
Its tiny flowers on grass-level  
Lying low in the land  
Overlooked as we take them for granted

I go where our underpinnings are  
Where I can experience initiations into interior spaces  
Like bird-song immersion, then dawn-break



**Breaking into secretly sealed seclusions  
And there it is: there are caves under the surface**

**Caves of new-found consciousness  
Additional spaces, spare-rooms, and yet  
They reveal themselves as undercover essences  
Informing ground-level, grounding us from below**



**Earth-orbits, of which we tend to be oblivious**

**Therefore I go where the silences are  
The unspoken and unheard words between us  
So I can help myself and all of us  
To look into the legacies of silent violence  
The invisible walls that stand between us**

**If I could reproduce this space in the city!  
Confront the glass ceilings and the obstacles  
And the marginalised sufferings of division!  
As if the separating social structures  
And the self-splitting selections that we live in  
Don't have any consequences!**

**Therefore I go where our caves are  
To have a closer look at our underpinnings  
And see what I can find, say or do  
To attend to this undercover cave-world  
The interior-wonder-world, origin-space  
Place of love, first love, first space  
Before womb got wounded, before all else!**

## **FREERING THERAPY**

**PAUL GORDON**

*There has never been anything like a properly resourced public therapy service in this country. And the limited provision of years gone by is starting to seem positively wonderful as austerity measures cut this even further to the bone. The link between mental suffering – especially anxiety and depression – and the woes of austerity – insecurity, uncertainty, poverty – could not be clearer.*

*It was in this context that a number of us came together in 2014 to set up the Free Psychotherapy Network. Like many therapists, I've always seen some people for low fees. This was a requirement of training – and rightly so, part of an*

*ethos of social responsibility. But I have also found myself seeing people for nothing when even the little became too much. The first time this occurred, Martin, my client, was reluctant to accept my offer, but I reasoned with him – and myself – that he could easily come and see me at the hospital where I was then an honorary therapist. Or he could save himself the journey and continue to come to my home. I saw him for several years and his connection with me kept him alive.*

*Seeing people for free can be a dirty secret among therapists, so strong is the idea that paying a fee is somehow good for the client. I've never had a problem charging people for what I do, given it's how I've chosen to make a living. But to say that money must change hands,*

*however little, is to buy completely into the notion that we only value what we pay for. Doesn't this invalidate the public provision of therapy and counselling, for example in hospitals and GP practices? Also, what's the difference, say, when someone is paying a couple of pounds and nothing?*

*I've never experienced any difference in the attitudes of people I've been seeing, according to how much or how little they are paying. And, of course, when people's circumstances change they have offered to pay.*

*Many organisations up and down the country provide low-cost or free therapy, but it seemed to us that there was a role here, too, for individual practitioners.*

*Our network is a recognition of a harsh social and economic reality and a modest proposal for how many of us could make a difference in people's lives. While most people find the support and understanding they need to live well in their everyday networks of friends, relatives, colleagues and community, many find themselves struggling with painful and debilitating experiences of anxiety, depression and self-doubt. All too often, people struggling with psychological insecurity are struggling also with financial and social insecurity. Everyone, it seems to me, should have the right to the kind of emotional help they need.*

*The FPN is very much in the tradition of the low-cost or free provision offered throughout*

*therapy's history. Psychoanalytic clinics set up in Berlin and Vienna in the 1920s, involving people like Erich Fromm, Karen Horney and Anna Freud, offered help for children as well as adults. In Vienna, the radical therapist Wilhelm Reich and his colleagues would even travel in a van to suburbs and rural areas, announcing their visits in advance and speak to anyone who cared to come along about sexual concerns.*

*Offering our services for free is not about charity – and nothing to do with bogus ideas of the “big society”. It is rather an act of solidarity with people who find themselves in situations of emotional trouble and material struggle, a contribution to social justice.*

*At the moment we are a small, loose network, mainly in London but*

*with supporters scattered around the country. We want very much to be a national network, encouraging and supporting one another, and invite people who share our ethos to get involved. Please look at our website for more on what we stand for and how to get involved:*

[freepsychotherapynetwork.com](http://freepsychotherapynetwork.com)

*Originally published in Therapy Today, April 2015.*



## PAINTINGS

### LAURIE FITZGERALD

*I've been creating art since I was a child; from designing my own fantasy characters and school caricatures, to minimalist landscapes inspired by music. There was also a small period of anime obsession! This was all supported a lot by a youth club I was a part of and KORI – a youth-enrichment charity based in Haringey that gave me a wealth of creative experiences and truly nurtured my creative spirit. I never would have picked up a paint brush in the way I do now had it not been for them. Such spaces are so important growing up and it's truly devastating that so many are shutting down.*

*My art now is influenced by a need to balance the scales so to speak within the watercolour medium and style. The double exposure effect is one used by many watercolour artists, however as a person of colour I wanted to see more of these beautiful images that looked a bit like me and the people I love.*

*In addition, I have a personal passion for the science of colour theory and of astrophysics and so I wanted to*

*explore how these could be used to illustrate something of ourselves as species; our isolation, our togetherness and our infinite potential.*

*It is my hope that through my art I can calm some of the storms in such stressful times, spread some much needed magic and bring some light to an often dark world.*

*Instagram: @laultlightdesigns*



**I am born, beautiful things to come**



Laulight's first wanderings – Purple Hope



Some things cut across all time and space

**CATHÉRINE LASALMONIE**

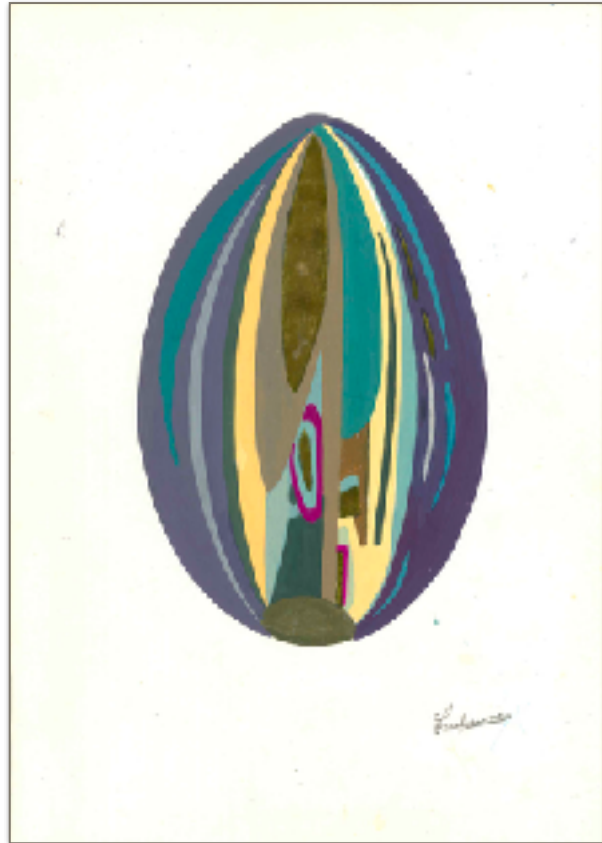

**Egg planet**

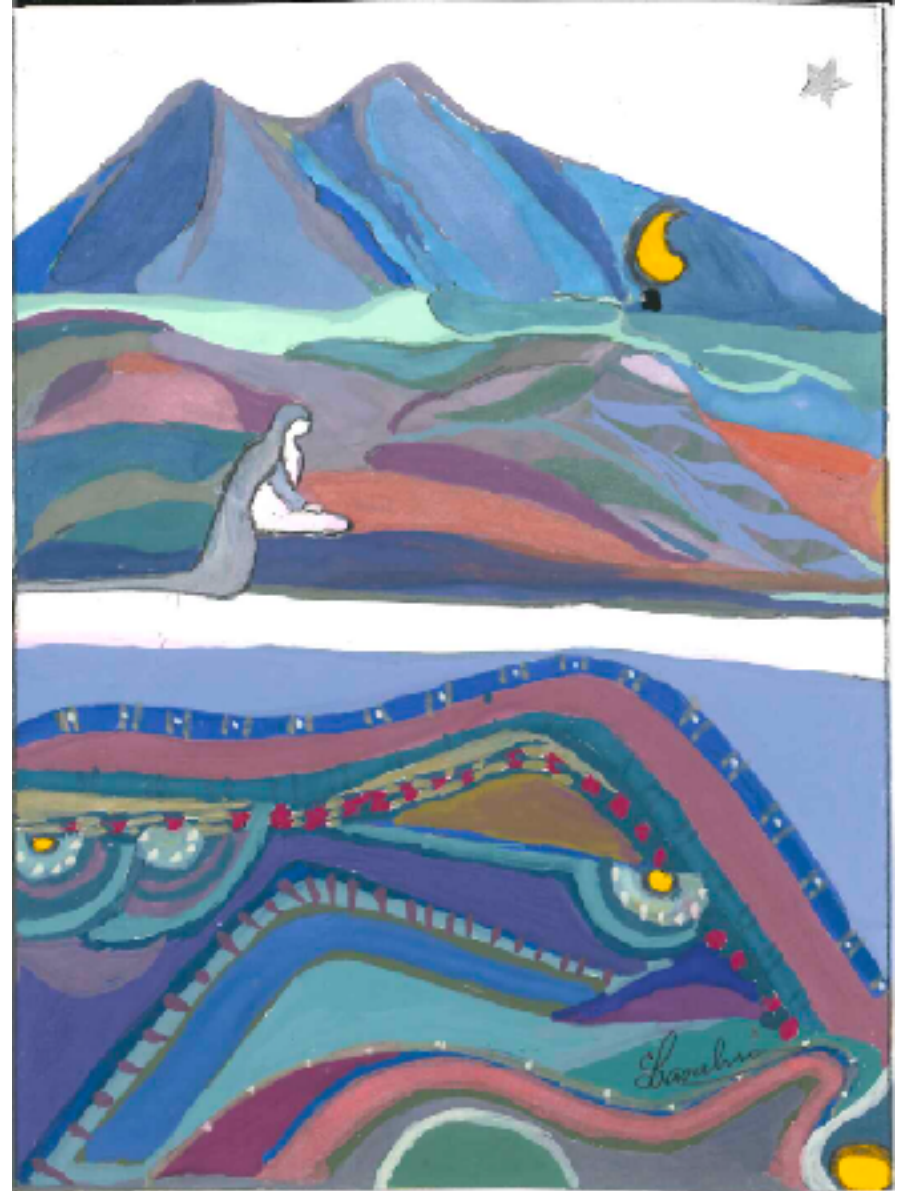

**The upper world and underworld**

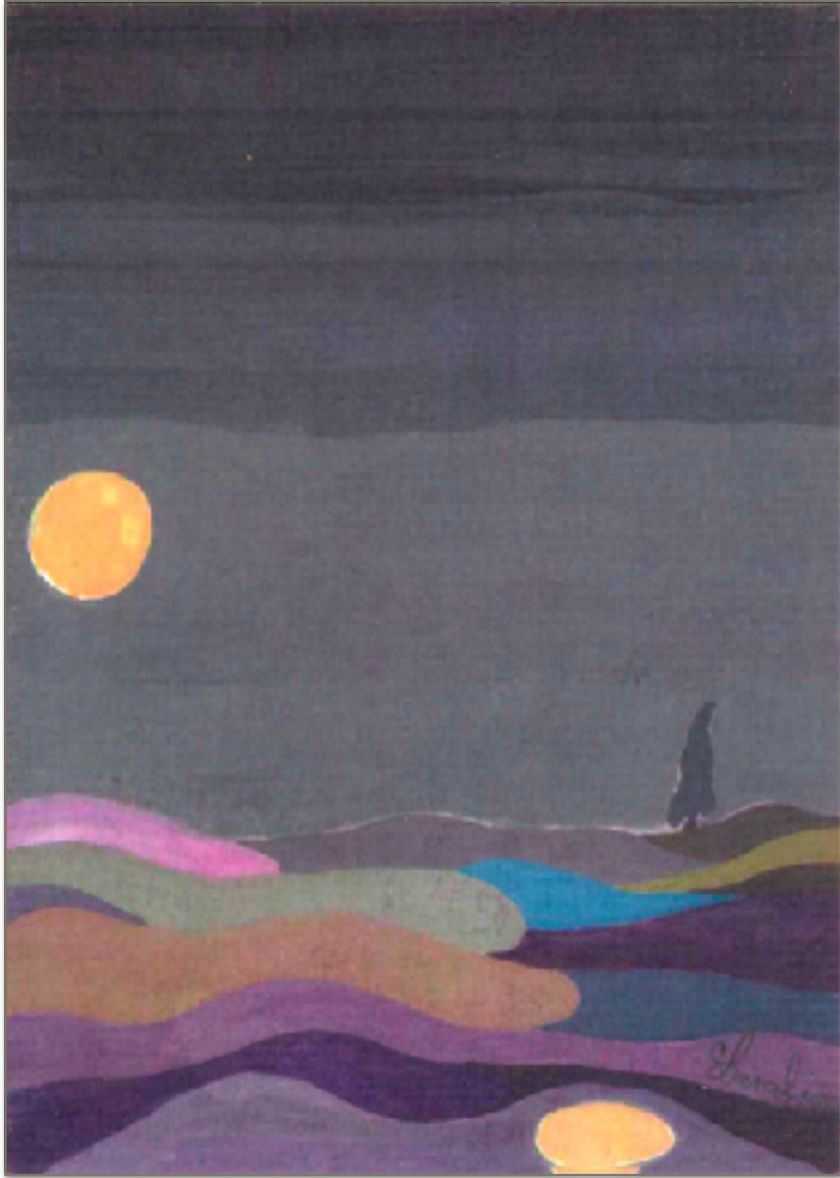

**Full moon on the sea**

**EILEEN LY**



**Eraser**

Acrylic On Board 84.8cm x 80.5cm



**Over the nest**

Acrylic On Board 92.4cm x 84.8

## **THE ANXIETY BIND** **JONATHAN ARMSTRONG**

*Inspired by R. D. Laing's book Knots (1972), which describes the "knots" and impasses in various kinds of human relationships.*

**JACK: I feel anxious**

**JILL: Try and relax**

**JACK: I can't relax**

**JILL: Take some deep breaths**

**JACK: I don't want to take some deep breaths**

**JILL: You NEED to relax**

**JACK: I can't RELAX! I NEED to find some strength ...  
some fight ... and reach some calm. Then I will learn to  
relax**



**DRAWING**  
**SASKIA TANSY**

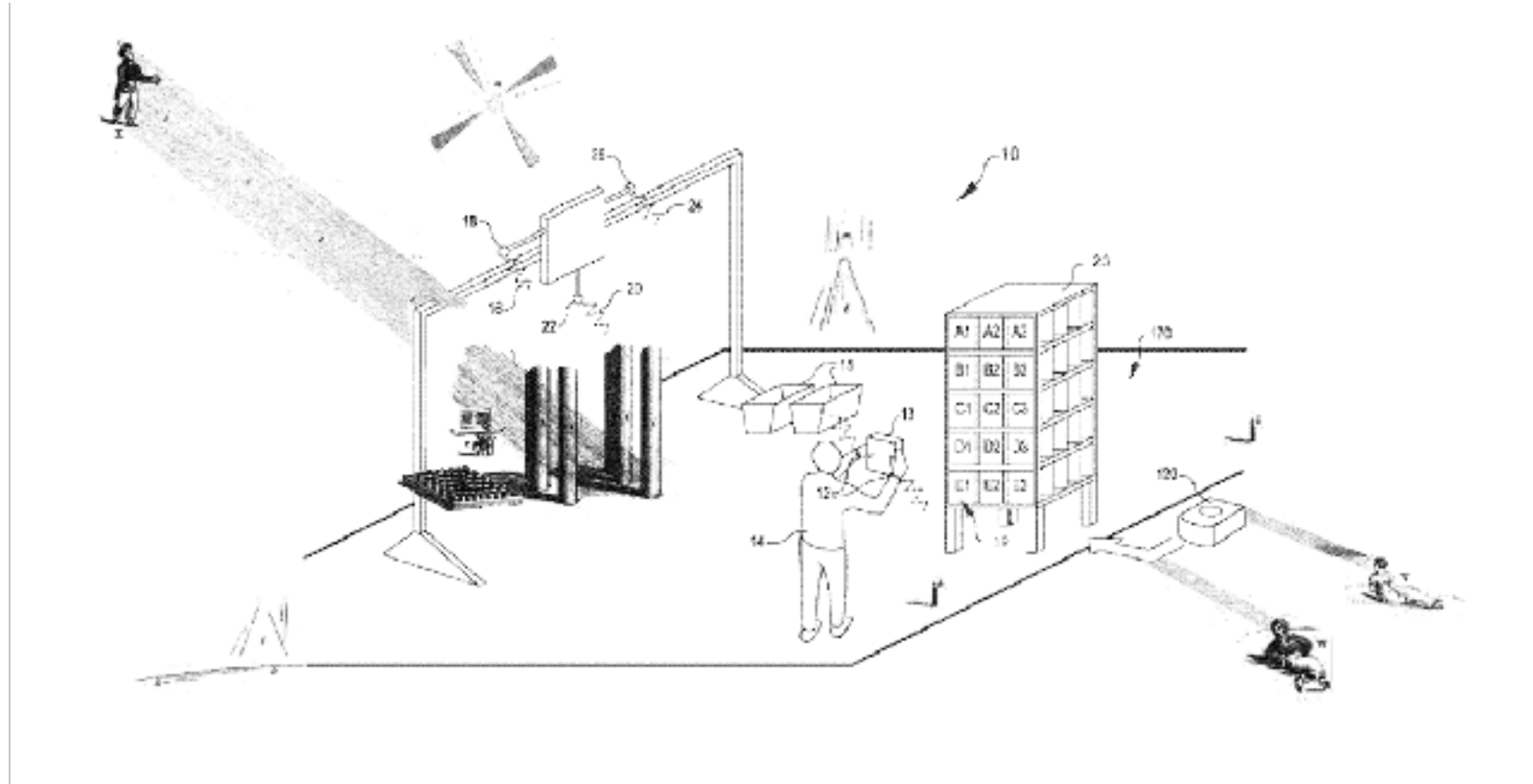

**Amazon loom**

**PHOTOGRAPHY**  
**ANDREA HEATH**



“...like someone who, walking at night along the banks of a stream, catches a glimpse in the water of a white face or a moving limb and turns quickly away, refusing to help or to search for help. We all see the faces in the water. We smother our memory of them, even our belief in their reality, and become calm people of the world; or we can neither forget nor help them. Sometimes by a trick of circumstance or dream or a hostile neighborhood of light we see our own face.”

Janet Frame

“I have given them your word, and the world has hated them because they are not of the world, just as I am not of the world. I do not ask that you take them out of the world, but that you keep them from the evil one. They are not of the world, just as I am not of the world.”

The Gospel of John

## MOVING BACK TO NOTTINGHAM AND FINDING LACAN BECKY COLES

“Take yourself seriously”

Rob White

I never used to be interested in taking myself seriously, although I always wanted to be around other people who kind of did. These tended to be people who didn't have the careers they might have had, the social circles or the children they might have had. People who hadn't made the art they might have. Squatters and activists who refused to, or didn't know how to, get on with these things. People who moved to get away.

At a protest organised by the group of an Italian Marxist friend,

**PA NEWSLETTER**



we were surrounded by the police and only allowed to leave, one by

one, after showing our passports and having our photos taken under a



bright light. I complained to him about having let this happen. Stop whining he said. As he got to the front of the queue, he couldn't find his ID card and for fifteen minutes he held up the process, checking and rechecking his pockets, taking all the crap out of them and putting it back in again. He wasn't trying to make a point. It genuinely took him that long to find it.

Some of my friends would like to have their problems solved, by psychoanalysis perhaps, and to be happier. Some think their suffering and outsidersness is unchangeable and others have fun with it. Whatever, they take their own discontent and inability seriously, as something of importance to them, and of importance to other people, as an important question.

Two years ago, I moved from London back to Nottingham, where I grew up. I started going to a Lacan reading group. We meet on Monday mornings and read a page or so of incomprehensible text. Sometimes Colin explains it to us or we get distracted and Graham talks about Kafka or something.

I think I moved back to try to become a serious person myself. I started psychoanalysis and for a whole year had nothing to say. I have more questions now. What about my discontent and inability can be changed and what can't? What about my awkwardness and anger and crapness do I want other people to take seriously? What does taking myself seriously mean for what I can do (or not do) in the world?

## REFERENCES

- Wright, Colin and Caine, Diana, eds (2017). *Perversion Now!* London: Palgrave Macmillan.
- Wright, Colin (2017). "When the Fun Stops, Stop!': Betting on Exclusion in the Era of Segregation." *The Lacanian Review: Hurly-Burly* 3, spring 2017.
- Caveney, Graham (2017). *The Boy with the Perpetual Nervousness: A Memoir of an Adolescence*. London: Picador.

## THE COST OF POSITIVE THINKING ROB WHITE

The ongoing TV series *The Americans* is about two Soviet agents working undercover in Washington D.C., where they live with their children as an ordinary suburban family. The show has plenty of intrigue and violence, but as the seasons have gone by it has developed themes of disenchantment, soul-searching and moral exhaustion. *The Americans* has become remarkable for its sadness. The mood can be sampled in this dialogue between the married spies:

**ELIZABETH:** You know what I wish as I fall asleep every night? That I wake up and not be worried.

**PHILIP:** About what?

**ELIZABETH:** Everything.

**PHILIP:** You can't live like that.

**ELIZABETH:** Show me another way.

The show makes it clear that really there is no other way for them, though a subplot has Philip attending Erhard Seminars Training – *est* for short – a programme of personal improvement which flourished in the U.S. in the early eighties (when *The Americans* takes place). With its emphasis on overcoming mental blocks in order to think positively, *est* helps Philip cope with his dangerous, demoralising life.

The ritualistic approach and relentlessly upbeat philosophy of *est* are recalled in *The Work* (screened at the PA in December), a documentary about a four-day group-therapy event at Folsom State Prison, California, organised by the male-bonding movement The ManKind Project and involving civilians as well as convicts. The cathartic, confrontational, immersive process depicted shares with *est* the idea that short-sharp-shock therapy can chase away personal demons and teach willing individuals to be less preoccupied and pessimistic, more enthusiastic and socially well-adjusted. One by one men are seen letting go of their inhibitions, writhing around boisterously as they

are mentored by more experienced participants into a better outlook on life. But there are also jarring moments in *The Work* when it seems as though the therapy is missing something important, or simply railroading somebody. One young man, an outsider not a prisoner, emerges from meditating under a blanket to say with tears in his eyes that he just remembered how happy he was as a child. It is a startlingly poignant incident because it confounds the expectation that the task is to tackle childhood trauma, past *unhappiness*. Before long, however, the man who glimpsed lost joy is, like everybody else, complaining about his inadequate father. The fragile, introspective

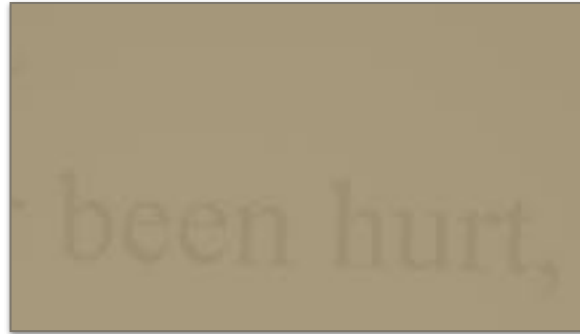

sorrow the man suddenly felt seems to have been ignored by the group, presumably because the notion that contentment may have come and gone, perhaps never to return, contradicts the affirmative ideology of self-help – which insists that, with the right motivation and above all the correct instruction, it is always possible to summon up hope and confidence, and so find the “other way” that the fictional Elizabeth in *The Americans* doesn’t believe exists. *The Work*’s jailhouse

ceremony can’t admit the possibility that sometimes hope is unrealistic, little more than a makeshift construct which screens off but can’t eliminate the negative truths of loss and grief and world-weariness.



Between 1974 and 1984 tens of thousands attended the two-week *est* course across the United States. Founded by Werner Erhard, the course drew from an eclectic range of sources, including scientology, consciousness-raising group work (Encounter Groups, T-groups, sensitivity training, Mind Dynamics), the Human Potential movement (Arica, Esalen), the self-help of

Norman Vincent Peale's *The Power of Positive Thinking* (1952) and Maxwell Maltz's *Psycho-Cybernetics* (1960), the Gestalt psychology of Fritz Perls, transactional analysis, the person-centred school of Carl Rogers, and scraps of eastern spirituality (Arica, Subud, Sufism, Zen). The seventies flourishing of esoteric psychologies of which *est* was a part alarmed some observers, including the anti-psychiatrist and PA co-founder David Cooper. In *The Language of Madness* (1978) he listed all the therapy books he saw in a shop in Cannery Row, California, scoffing at their methods. "I've no

doubt," he wrote, "that after some of these experiences some people feel better, or begin to 'feel,' or feel more 'real' – or whatever the ideals of capitalism prescribe for them."<sup>1</sup> The authors of *The Psychiatric Society* (1982) claimed that in the era of mental-hospital deinstitutionalisation, finding-yourself fashions were wacky in appearance but conformist in essence. These lifestyle fads, which the writers called "therapy for the normal," might as well have been directly outsourced from asylums for the purposes of behavioural programming, except that in a hypocritical liberal society it couldn't

be seen to work like that. "No longer a society in which psychiatry takes care of a few patients," America was transforming into "an organization of everyday life in which manipulative techniques, more often than not developed and popularized by mental medicine, became coextensive with all aspects of social life."<sup>2</sup> *The Psychiatric Society's* argument was like the assertion in *Limits to Medicine* (1976) by Ivan Illich that the modern medical rigmarole of tests and checkups robbed people of their autonomy in the name of health.

The *est* course was intensive and gruelling. Participants were

---

<sup>1</sup> David Cooper, *The Language of Madness* (London: Allen Lane, 1978), p. 119.

<sup>2</sup> Robert Castel, Françoise Castel and Anne Lovell, *The Psychiatric Society*, trans. Arthur Goldhammer (New York: Columbia University Press, 1982), p. 320.

forbidden for hours on end from taking toilet or cigarette breaks. The course leaders were belligerent and afterwards everybody said the guided meditations, known as “processes,” were emotionally exhausting. (Former mental patients and anybody who admitted to being in therapy but not making progress weren’t allowed to enrol.) Attendees were expected to talk openly about their unhappiest experiences but any hint of being a victim was loudly belittled. As the days went on, the trainers inculcated a philosophy. The mind was described as an information stack, “a

linearly arranged, multi-sensory, total record of successive moments of now.”<sup>3</sup> Troubling events in a person’s past were termed “items,” which needed to be exposed and then forgotten so that the “item-holder” could start living in the here and now. The disposal of items was called “fully experiencing the experience,” which brought home a heightened sense of responsibility. Participants learned that they were actually the cause of their *entire existence*. “However it is for you,” the course leader explained, “that’s the way you’ve set it up and no amount of

resistance will change that. Now you have a choice. You can keep resisting. Or you can choose it. You can bitch about it. Or you can take responsibility for it. If you are willing to acknowledge that you are the cause in the matter, then you can be responsible for it, instead of having it run you.” Responsibility meant acceptance, while “resistance only makes things continue.”<sup>4</sup> Protest against the Vietnam War was an example of this principle of persistence; it caused the downfall of Lyndon Johnson only for Richard Nixon to replace him and escalate the

---

<sup>3</sup> Robert A. Hargrove, *est: Making Life Work* (New York: Delacorte Press, 1976), p. 112.

<sup>4</sup> Adelaide Bry, *est: 60 Hours That Transform Your Life* (London: Turnstone Books, 1977), pp. 50, 52.

war.<sup>5</sup> At worst, “you become what you resist.”<sup>6</sup> The relationship between person and environment was understood by *est* in terms of agreements rather than laws. For example, the trainer said, “institutions have an agreement going with gravity, and when you try to knock them over, they come tumbling down on top of you.”<sup>7</sup> Agreements were unavoidable but anybody could take the step of eliminating the feeling of subjection to them by actively *choosing* the forcible agreements.

Above all, *est* was a doctrine that renounced disobedience. In so doing it inverted the ideals that radical writers like Cooper and R. D. Laing held dear; and *est* welcomed, even in the very same terms, what these malcontents dreaded.

Laing’s great fear was that the asylum could somehow worm its way into people as a mentality. “In the best places,” he wrote in the 1966 preface to *The Divided Self* (1960), “where straitjackets are abolished, doors are unlocked, leucotomies

largely foregone, these can be replaced by more subtle lobotomies and tranquillizers that place the bars of Bedlam and the locked doors *inside* the patient.”<sup>8</sup> He returned to the theme in *The Politics of the Family* (1971): “Man does not always need bars for cages. Ideas can be cages too. Doors are being opened in mental hospitals as chemical constraints become more effective. The doors in our minds are the most difficult to open.”<sup>9</sup> Cooper likewise warned of “a miniaturization of the

---

<sup>5</sup> Hargrove, *est*, p. 79.

<sup>6</sup> William Warren Bartley III, *Werner Erhard – The Transformation of a Man: The Founding of Est* (New York: Clarkson N. Potter, 1978), p. 44.

<sup>7</sup> Hargrove, *est*, p. 97.

<sup>8</sup> R. D. Laing, *The Divided Self: An Existential Study in Sanity and Madness* (Harmondsworth, Middlesex: Penguin Books, 1966), p. 11.

<sup>9</sup> R. D. Laing, *The Politics of the Family and Other Essays* (New York: Pantheon Books, 1971), p. 58.

hospital if the logic of the hospital is not broken.”<sup>10</sup> In *est*, however, the intake of restrictions was the *goal* rather than the feared danger. Trainers worked to make “trainees identify with and internalize the training rather than merely comply.”<sup>11</sup> In the *est* view, imprisonment was unavoidable and therefore to be embraced. According to the training script, “There are two kinds of prisons – maximum security prisons, with bars; and minimum security prisons, like here and on the outside, with doors.”<sup>12</sup> And Werner Erhard actually developed an outreach

program for American penitentiaries, which he led himself. The writer and *est* graduate Adelaide Bry went to a correctional facility in Lompoc, California to witness the results. She met men who had come to accept they were the sole engineers of their situation. Instead of dreaming of freedom, they lived for the present. “By being in the here and now, and by accepting that ‘here’ meant three sets of barbed wire, guard towers, and restricted movement, then they had choices.” A man convicted of armed robbery said he used to long for release but after the training he was

able to go with the flow because he finally understood that wishes didn’t change anything. Bry was moved to find “people leading caged lives with integrity,” and she reported a strange feeling as she left Lompoc. “When I left the prison and heard the electronic lock shut behind me, I had the fleeting sense that I was being locked *out*,” she wrote, as though a prison run on *est* lines was the perfect place to be.<sup>13</sup>

The premise of one of Erhard’s major influences, *The Power of Positive Thinking*, was simple and stern: “In the last analysis the basic

---

<sup>10</sup> Cooper, *The Language of Madness*, p. 167

<sup>11</sup> Sheridan Fenwick, *Getting It: The Psychology of est* (Harmondsworth, Middlesex: Penguin Books, 1977), p. 120.

<sup>12</sup> Hargrove, *est*, p. 96.

<sup>13</sup> Bry, *est*, pp. 85, 89–90.

reason a person fails to live a creative and successful life is because of error within himself. He thinks wrong. He needs to correct the error in his thoughts. He needs to practice right thinking.”<sup>14</sup> As in many self-help teachings, the links between person and world were ignored. In one way this doctrine boosted the individual’s autonomy by focusing on what he or she thought and did in any situation, irrespective of external factors. But in another way it overloaded and violated personal responsibility because it regarded the factors which in reality stopped somebody from being effective – not only physical obstacles like barbed wire and guard towers, which were bad enough, but

also inward factors like the bitter anger caused by powerlessness – as being under the person’s control. Self-help in the extreme form of *est* attributed total responsibility for experience to the individual, who therefore had to banish disappointment, resentment, and any other useless negative feeling or never have a life that wasn’t weighed down – which anyway *est* then defined as a choice rather than an affliction.



It was a major achievement of the PA founders to show that disingenuous family groups could turn the idea of

freedom into a con trick. Time and again in *Sanity, Madness and the Family* (1964) Laing and Aaron Esterson observed a young person caught in the snare of scapegoating doublespeak. One young woman tried to explore her predicament only to be drowned out by her mother’s perverse and manipulative pontificating:

**MOTHER: Well I think Mary’s idea of being independent – it doesn’t mean being able to do what you want to do, it means being able to model a course for your life – finding ways and means of carrying it out. But to be independent doesn’t mean you walk out the door and don’t tell anybody where you**

---

<sup>14</sup> Norman Vincent Peale, *The Power of Positive Thinking* (New York: Prentice-Hall, 1952), p. 213.



are going, and you're worried stiff about where she is – that's not independence to me.

MARY: I didn't walk out thinking I was going to be independent – for goodness' sake—

MOTHER: Oh I don't mean at the time you went away.

INTERVIEWER: But you wouldn't see that as inconsistent with being independent would you?

MOTHER: Well it may be independence of a kind but it's not the right kind of independence. She can be independent. She can make her arrangements and then say, "I'll go away a week on Monday" or whatever it was – "I've got a

nice job so-and-so" – and let's know and go decently.

INTERVIEWER: But supposing she didn't say that sort of thing to you?

MOTHER: Well if she didn't want me to know she could say, "Well, look, Mummy, I'm going away, but I'd rather you didn't know or bother about where I'm going." I would say, "All right then." That's still the right way isn't it?

MARY: But when do I go the wrong way then?

MOTHER: When you leave us wondering how you are getting on and what you are doing.

MARY: When did I do that?

MOTHER: You've never done it, it's the way you're talking about doing things – about independence.

Laing and Esterson commented that Mary's insensitive parent was "impervious to the point that Mary repeatedly makes, that she does not want to be ordered to be autonomous."<sup>15</sup> In *Psychiatry and Anti-Psychiatry* (1967), Cooper likewise described how the parents of one of his patients sent such mixed messages about their son's adulthood that he never felt comfortable leaving home. He would rush back from university on a whim only to prepare immediately for the

---

<sup>15</sup> R. D. Laing and Aaron Esterson, *Sanity, Madness and the Family: Families of Schizophrenics* (Harmondsworth, Middlesex: Penguin Books, 1970), pp. 219–20.

return journey in a state of panic.  
“The liberation he was offered was in fact a Trojan horse,” Cooper wrote.  
“To act freely entailed his submission to the injunction to be free: freedom and unfreedom were finally equated.”<sup>16</sup> The multitude of positive-thinking therapies, of which *est* and to a lesser degree The ManKind Project are only two, also demand compliance as the price of choice – and in this way one side of a deceptive bargain cancels the other one out.



<sup>16</sup> David Cooper, *Psychiatry and Anti-Psychiatry* (London: Paladin, 1970), pp. 74–5.

## THE WORK NICK MERCER

The showing of the documentary film *The Work* produced one of the best discussions I've experienced at the PA. The evening was well-attended and the ensuing discussion was lively and inclusive, i.e. everyone got a chance to speak.

It provoked particularly powerful feelings for me as it recalled my own experience of standing and participating in similar circles, specifically an incident that happened at the very beginning of a weekend like the one shown.

It was 2001. I was working in Reading gaol – gone now, but back then a young offenders' remand prison. I was managing a twelve-step treatment programme for young men

with drug or alcohol problems. I asked a friend with experience of addiction if he'd be willing to fill the outside-speaker slot on our treatment program that week but he said he couldn't because he was staffing a men's weekend and needed to prepare. I expressed polite curiosity and he told me it was a ManKind Project weekend (the same guys who facilitated the Folsom prison work shown in the documentary). He described it as a kind of rite of passage for men; but said little else.

Foolishly, I said, "I'd like to do that one day," despite my inner sceptic having already dismissed such a possibility – judging the event, on scant or nil evidence – as a con for the gullible. "Why not this weekend?" he said, "I'm busy!" I said immediately.



"Well, if you're busy, fair enough ... but if that's just a defence – your stock response to anything new – it might be worth thinking about." Beneath my indignant dismissal of his suggestion, it got to me, because it was true. I recoiled from anything threatening change to me even as I cheerfully

urged young men on the prison programme to realise their potential by launching themselves into the unknown of a new way of life. Unusually, I heard myself – almost from some vertiginous distance – saying, “Yes, I’ll do it.”

So, I found myself waiting outside Maida Vale tube station that Friday evening to meet my fellow participants on this strange adventure, full of trepidation and clutching a huge bag of food I’d been ordered to bring for the communal kitchen. There were four of us – a journalist, a healer, and an Italian businessman. All, like me, were struggling to navigate the mysteries of their own masculinity, and often feeling alone and mired in it. By the time we reached our destination, an old RAF station at Sopley in the New Forest, we had all

shared our stories and grown a little closer and were looking forward to the adventure ahead though we had no idea what it would be like. Most of our ideas of male initiation rites were culled from *The Emerald Forest* or *A Man Called Horse*. Little were we to know it wouldn’t be that easy.

We arrived in good time at a rather forbidding padlocked gate, rang the bell and waited ... and waited, our small group growing increasingly nervous against the gathering gloom.

Eventually, a man appeared walking briskly down the pock-marked concrete drive from a clump of forlorn-looking outbuildings. The military bearing of his gait seemed in keeping with the iron-grey cropped head, the fatigues and the clipboard he clutched. On arrival at the gate he gave us a peremptory glance and said

simply, “Yes?” in a clipped South African accent (which did little to dispel our initial misgivings).

“We’ve come from London,” we chorused and enthused as one.

“We’ve come for the adventure – together!”

“What time were you told to be here?”

“5 o’clock” we said.

“What time is it now?”

“It’s 4:45pm” said the healer, hurriedly squinting at his watch.

“Come back at 5pm,” he said, and turned on his heel to go.

“OK,” said my erstwhile comrades sheepishly, “We’ll drive round the block – shall we?” This last muttered ineffectually in the vague direction of our oppressor, as they scurried back to the sanctuary of the car – an attempt to placate.

“Hang on,” I said, as I felt a cold fury rising through my limbs like magma from a suddenly awakened ancient volcano, long thought dormant. “No-one’s going anywhere.” They froze; half-in, half-out of the car. I drew myself up to my full height, squared my shoulders and turned to address our inhospitable host in no uncertain terms – “You,” I said with cold authority; but he’d already gone.

So I was left spluttering in impotent rage, shot by both sides, feeling equally bullied by the paramilitary and betrayed by my companions, and, as the fireworks of rage began to dim, an increasing sense of bleak loneliness, and, if truth be told – shame. As I climbed back into the awkward silence of the car to sit in sullen misery, unable even to make eye contact with the others, something

else arose within me that implied something extremely uncomfortable – the sheer familiarity of it all – that sense of exile, injustice and muffled rage was mine, no-one else’s ... little to do with the actual detail of what had just happened. Ditto, the perverse comfort derived from that sense of absolute aloneness. A man had simply told us to come back at the designated time and my fellows had agreed to do just that. The rest was my projection – one I’d made earlier. Unusually, a thought came to me that I needed to be there, that this was “the work” – and it broke the dam. My whole body changed as that stiffness flowed out of me. I suddenly knew I was in the right place and was eager for more. The rest of that weekend didn’t disappoint though the specific detail must remain a secret as we were asked to respect

the content of the weekend and were given the simple reason, “Don’t spoil it for the men who come after you”... because it is a kind of story – an odyssey of sorts. Some of it about finding compassion and acceptance for that lost, furious boy and welcoming him home.

Today, when I conjure the memory of that moment of arrival, I cannot help but imagine it – more farce than tragedy – not so much King Lear and his fool out on the stormy heath – or even Hamm in *Endgame* flushed with the grandiosity of his own misery – but more *Withnail and I* under the pounding rain, Withnail beseeching the farmer – “Are you the farmer? You must help us; we’ve come on holiday by mistake!”

What I learned that weekend and on similar groups and weekends

over the following years has informed not just my practice but how I live. For me, the experience had the opposite of a shelf life. Rather than wear off, it grew deeper with the years. Something happened that allowed me to cast off the mind-forged manacles of my cynicism and faux world weariness, the contempt prior to investigation that is always companion to a fear of life, and simply surrender and embrace the weekend. I still remember it with great affection and etched-in intensity. It gave me something I hadn't experienced previously. There was something about finding oneself in a circle of sixty men that left no hiding place but paradoxically exuded safety – a sacred place where the shadow could fully manifest and be assimilated.

I hasten to add I didn't leave there shrived of my stuff, I didn't "go clear" or whatever, but I left there having rediscovered my courage, with a respect for honesty and accountability and a little more acceptance of my own frailties (which of course were commonplace and shared by practically all the other men there, the same fears and doubts, the same acting out; I was not alone – who knew!).

I'm told the Masai, who still practice rites of passage in order to initiate young men into adulthood, have a saying – "Uninitiated men will burn down the village – just to keep warm." After working with men in prison for many years that same absence of any guidance is a constant trope that confirms the truth of this, hence my support for initiatives like

*The Work*. If you haven't already seen it, and you're interested in group work outside the confines of traditional therapy, the therapeutic value of one human helping another, then I urge you to go and see it.

#### A FOOTNOTE

The other aspect of *The Work* which felt particularly relevant to the PA for me was it also recalled one of the great regrets I experienced on the PA training – the loss of the experiential group when I moved upstairs from the introductory course to the training proper. In the introductory year our seminars on Heidegger, Freud, Buddha or whatever were preceded by an experiential group facilitated by Marie-Laure Davenport, a vastly experienced therapist with a great knowledge of groups. It gave us a safe



space where we could show up and say how we felt, explicate and explore dynamics and challenge each other in a respectful way.

Consequently, we could hear and engage with the following seminars with clarity because we'd cleared all the psychic debris of that particular day and the group had an idea of where we were as individuals,

what difficulties we were facing in our own lives outside that space.

Proof of the efficacy of this system is that I remember the content of those seminars, from Joe Friedman on Leslie Farber to Paul Gordon on Heidegger – with greater recall than much of the stuff we discussed upstairs in later years. Those discussions seemed more alive, somehow. I have come to the conclusion that an experiential space is essential for a training that revolves around community and holds that our distress or joy is contingent on our immediate environment as well as our history. Individual supervision and therapy are only a part of this work. There isn't a professional environment I've worked in over the last twenty-five years that hasn't understood this and begun and ended the day with

some sort of formal check-in and check-out. It keeps the decks clear of resentment and allows us to best serve others. Enough for now, more of these matters later...

---

**Published by the  
Philadelphia Association  
philadelphia-association.com  
0207 794 2652  
office@philadelphia-  
association.org.uk**